

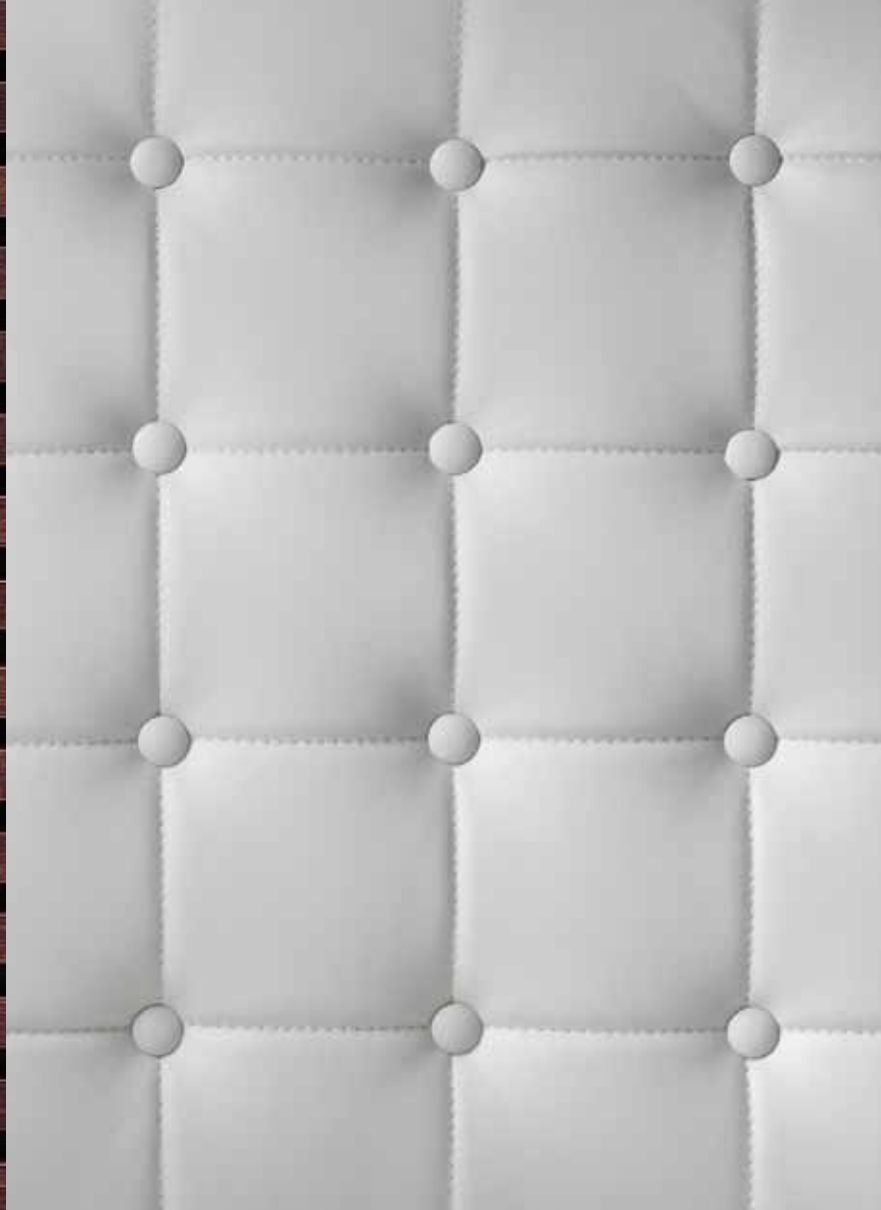

TAIKO



*ar*tom



TAIKO

Design F.V. Tomson

TAIKO è il termine giapponese che indica il tamburo, e come tutti gli strumenti musicali, solo se è ben costruito, il suono che produce sarà armonioso ed equilibrato.

Tutti gli oggetti producono un suono quando li sfioriamo, li tocchiamo, quando li usiamo. **TAIKO** è un insieme di materiali assemblati per funzionare in armonia, per “suonare” in armonia: il suono del piano di legno, profondo e rassicurante; quello della pelle, ovattato e morbido; quello del metallo della struttura, acuto e costante che mai cede. Tutto questo si armonizza insieme e il risultato è un suono dal timbro sicuro, affascinante e seducente: la voce di **TAIKO**.

TAIKO is the Japanese word for “drum,” and, like any other musical instrument, this drum will make a balanced and harmonious sound only if it is well built.

All objects produce a sound when they are lightly stroked, touched, used. **TAIKO** is a combination of materials assembled to work in harmony, to “sound” in harmony: there is the desktop sound of wood, deep and reassuring; the sound of leather, muffled and soft; the sound of metal structure, clear and constant, never yielding. All these sounds work together in harmony and the result is a voice that is solid, fascinating and seductive: the voice of **TAIKO**.



TAIKO è caratterizzato da un scrupoloso controllo dei tratti, la forma minimale e gli elementi tecnici, incontrano la ricchezza dei dettagli e la raffinatezza dei particolari, che decorano e vestono la sua prestigiosa presenza. Le preziose essenze che rivestono i piani, l'ampio inserto di pelle che rende caldo ed accogliente lo spazio di lavoro, le pregiate finiture che definiscono l'incontro delle superfici e i basamenti che concludono in modo raffinato l'accosto a terra, tutti dettagli che si apprezzano quando ci si avvicina e si entra in contatto con TAIKO.

ELEGANZA E RIGORE.



TAIKO combines scrupulous control of lines, minimal shapes and technical elements with the richness of elegant detail to create a presence that personifies prestige. Precious wood covers the surfaces, ample use of leather makes the workspace warm and welcoming, rich finishing touches define the connections between surfaces and floor, details inviting close contact to appreciate the elegance and refinement of each TAIKO piece.

ELEGANCE AND RIGOUR.







10

L'ufficio TAIKO acquista ancora di più prestigio con l'inserimento del contenitore. Come per la scrivania, lo sbalzo laterale del piano è l'elemento caratterizzante. Rialzato dal contenitore vero e proprio, il piano offre una grande superficie, ideale per mettere in risalto vasi, sculture, oggetti da collezione; ma anche solida base per raccogliere libri o documenti di lavoro.

I contenitori nella parte bassa offrono un notevole spazio in cui riporre volumi ingombranti o materiale d'uso,

A TAIKO office becomes even more prestigious with the addition of a TAIKO storage unit. Like the desk, the unit's special projecting feature combines with the solid, uninterrupted surface that runs the length of the unit itself. The top is raised from the storage unit and is ideal for show-casing vases, sculpture and collected objects, it is also a solid shelf to hold books or work files.

Underneath, the unit provides ample space for the storage of bulkier volumes or office supplies.







La grande libreria TAIKO è caratterizzata da un contenitore verticale che funge da vero e proprio armadio. Consente di riporre eventuali indumenti, permettendo così di mantenere nel proprio ufficio un ordine rigoroso. I contenitori laterali, con ante a ribalta offrono uno spazio per l'archiviazione, capiente e facilmente accessibile. Una vasta zona a giorno dedicata a libreria è composta da solidi ripiani in vetro ideali per accogliere preziosi volumi o "personali racconti".

The large TAIKO bookcase has a vertical unit that functions as a full closet. Made to store garments, it ensures a neat and uncluttered office. The side storage units with tilting doors, provide ample and easily accessible filing space. A large, open area is filled with solid glass shelves, ideal for precious volumes or personal souvenirs.



18



PRESTIGIO.

Possente nell'aspetto ed estremamente curato nei dettagli, TAIKO è un oggetto "colto".

Il progetto di TAIKO passa attraverso un continuo confronto tra passato e presente. La ricerca dell'eccellenza tecnica ed un profondo studio delle proporzioni formali sono confluiti in TAIKO in modo armonico. TAIKO soddisfa pienamente i requisiti di funzionalità che un arredamento da ufficio deve avere e, allo stesso tempo, la bellezza e l'eleganza delle sue forme, donano a chi lo sceglie, quel piacere e quella soddisfazione che solo certi arredi di prestigio sanno dare. Prestigio è la parola che più di ogni altra riesce a comunicare l'anima di TAIKO.

La possibilità di vestire con listelli di legno massiccio il frontale della scrivania conferisce a TAIKO un aspetto rigoroso e pulito, e lo rende perfettamente in sintonia con gli ambienti razionali dell'architettura contemporanea, ma la scelta del frontale con l'imbottitura in pelle, con la preziosa lavorazione capitonnè, aumenta l'eleganza della scrivania e la rende adatta per essere collocata in ambienti classici e lussuosi.

PRESTIGE.

PRESTIGE. Powerful looking, with extremely polished details, TAIKO is a "cult" line of furniture.

The TAIKO concept continually melds past and present. Technical excellence and careful consideration of formal proportions come together in TAIKO in a harmonious way. TAIKO completely fulfils the functional requirements of office furniture while, at the same time, giving the person who chooses it the pleasure and satisfaction that only beautiful and elegant prestige furniture can provide. Prestige is the word that, more than any other, expresses the spirit of TAIKO.

The desk front may be covered with solid wooden laths to place TAIKO perfectly in synch with the minimal lines of modern architecture. But the choice of a leather padded front panel with refined button-tufted finish adds to the elegance of the desk and allows it to fit into a more classically luxurious office environment.







26

La scrivania TAIKO si caratterizza per il grande piano a sbalzo laterale. Lo spessore elevato e la struttura portante rendono solido e stabile il piano di lavoro. La base centrale di appoggio dichiara subito le qualità che contraddistinguono questo prodotto: eleganza e rigore.

A TAIKO desk is characterised by the large, solid, projecting desktop. The thickness of the piece and its supporting structure ensure the solidity and stability of the work surface. The central base immediately confirms the qualities that mark this product: elegance and rigour.









**SCRIVANIA (ESCLUSO FRONTALE), TAVOLI RIUNIONE, CASSETTIERA PORTANTE
DESK (EXCEPT FRONT), MEETING TABLES, PEDESTAL**

IMPIALLACCIATO / VENEERED

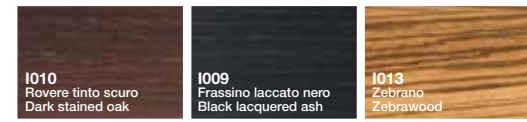

LACCATO LUCIDO / BRUSHED LACQUERED



**SOLO CASSETTIERA PORTANTE
ONLY PEDESTAL**

LACCATO / LACQUERED

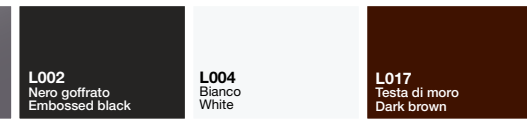

**FRONTALE SCRIVANIA
FRONT DESK**

LISTELLI / STRIPS

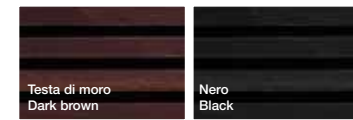

PELLE / LEATHER

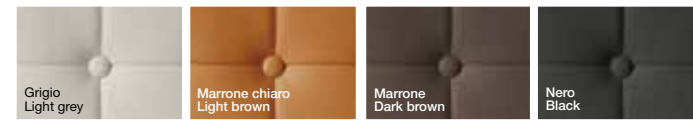

**CONTENITORI
UNITS**

**STRUTTURA
STRUCTURE**

LACCATO / LACQUERED

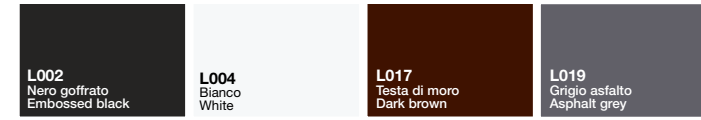

**TOP E ANTE
TOP AND DOORS**

IMPIALLACCIATO / VENEERED

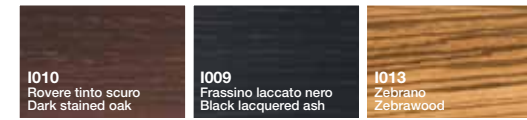

LACCATO LUCIDO / BRUSHED LACQUERED

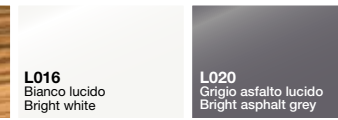

**ANTE
DOORS**

LISTELLI / STRIPS

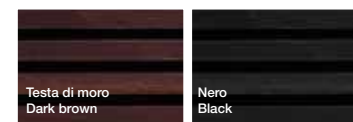

**LIBRERIA
BOOKCASE**

**SCHIENE
BACKS**

LISTELLI / STRIPS

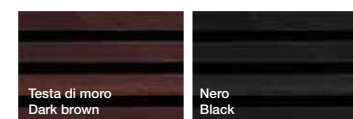

**SCHIENE CON INCISIONI
BACKS WITH ENGRAVING**

IMPIALLACCIATO / VENEERED

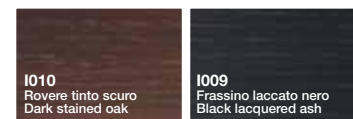

LACCATO / LACQUERED

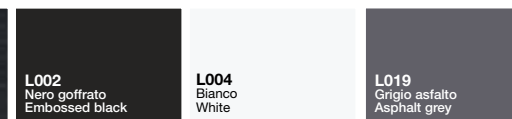

**DIVISORI, TOP E FIANCHI FINITURA
MIDDLE PANELS, FINISHING TOP AND SIDES**

IMPIALLACCIATO / VENEERED



LACCATO LUCIDO / BRUSHED LACQUERED

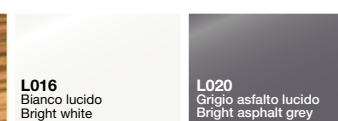

Taiko (H - L - P)

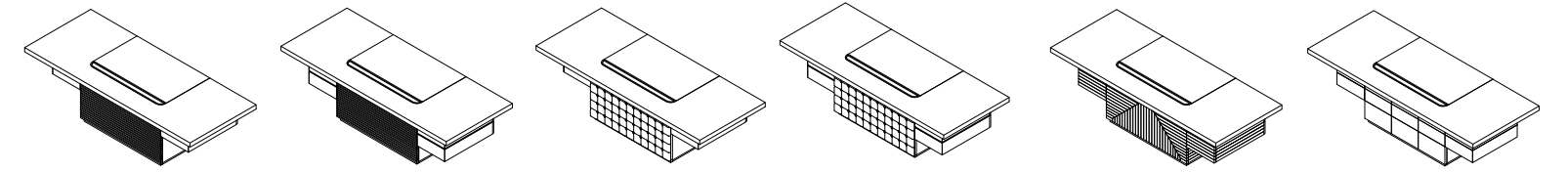

TK220R/1 220 - 100 - 75
TK250R/1 250 - 100 - 75
TK220R/2 220 - 100 - 75
TK250R/2 250 - 100 - 75
TK220P/1 220 - 100 - 75
TK250P/1 250 - 100 - 75
TK220P/2 220 - 100 - 75
TK250P/2 250 - 100 - 75
TK220I/2 220 - 100 - 75
TK250I/2 250 - 100 - 75
TK220L/2 220 - 100 - 75
TK250L/2 250 - 100 - 75

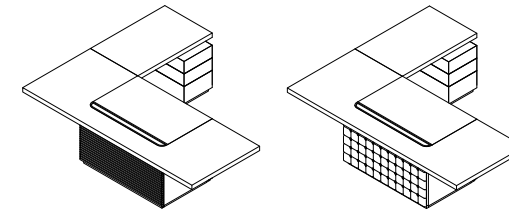

TK250RA2 250 - 200 - 75
TK250RA1 250 - 200 - 75
TK250PA2 250 - 200 - 75
TK250PA1 250 - 200 - 75

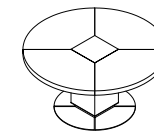

TK150 ø 150 - 75

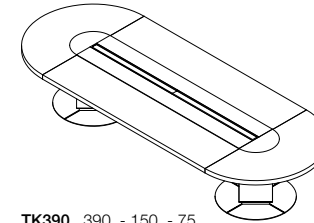

TK390 390 - 150 - 75

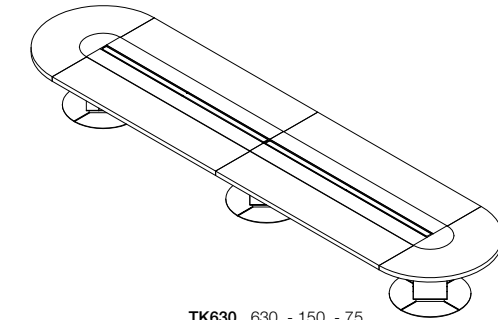

TK630 630 - 150 - 75

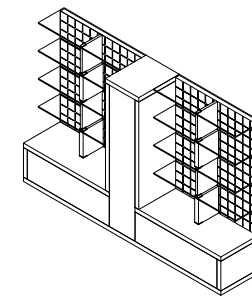

TK3000IC 300 - 60 - 200

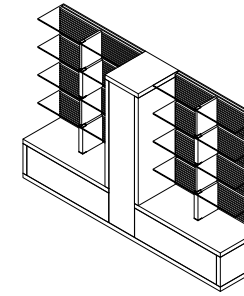

TK3000R 300 - 60 - 200

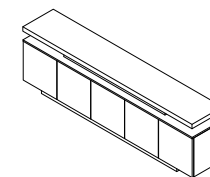

TK2000I 200 - 45 - 75
TK2500I 250 - 45 - 75

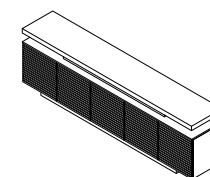

TK2000R 200 - 45 - 75
TK2500R 250 - 45 - 75

ULTOM S.P.A.
VIA POSTUMIA DI LEVANTE, 47
35013 CITTADILLA (PD) ITALY
TEL.+39 049 5971877
FAX +39 049 9400650
www.ultom.com
ultom@ultom.com